

**CIMC TIANDA 中集天达**



深圳中集天达物流系统工程有限公司  
Shenzhen CIMC Intralogistics Systems Co., Ltd.

华南基地: 广东省深圳市宝安区福海街道福园二路9号中集天达工业园  
South China Base: CIMC Tianda Intralogistics Industrial Zone, No.9, Fuyuan 2<sup>nd</sup> Road,  
Fuhai Street, Bao'an District, Shenzhen City, Guangdong Province P.R.China

华东基地: 江苏省昆山市张浦镇建德路658号  
East China Base: No. 658 Jiande Road, Zhangpu Town, Kunshan City,  
Jiangsu Province, P.R. China

网址/Website: www.cimc-tdholding.com  
邮箱/E-mail: hua.jiang@stas.cimc.com



中集德立物流系统(苏州)有限公司  
CIMC Pteris Global Logistics System (Suzhou) Co., Ltd.

地址: 江苏省昆山市张浦镇建德路658号  
Address: No. 658 Jiande Road, Zhangpu Town, Kunshan City, Jiangsu  
Province, P.R. China

网址/Website: www.cimc-pterisglobal.com  
邮箱/E-mail: hua.jiang@stas.cimc.com

昆山中集物流自动化设备有限公司  
Kunshan CIMC Logistics Automation Equipment Co., Ltd.

地址: 江苏省昆山市张浦镇建德路658号  
Address: No. 658 Jiande Road, Zhangpu Town, Kunshan City, Jiangsu  
Province, P.R. China

邮箱/E-mail: hua.jiang@stas.cimc.com

**箱式输送分拣系统解决方案**  
Workbin Conveyor Sorting System Solutions



多楔带滚筒输送机  
Multi Wedge Belt Roller Conveyor

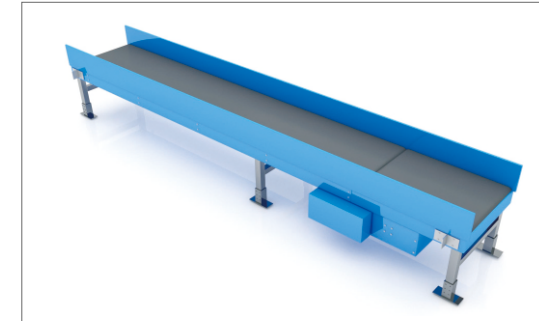

皮带输送机  
Belt Conveyor



转弯皮带输送机  
Turning Belt Conveyor

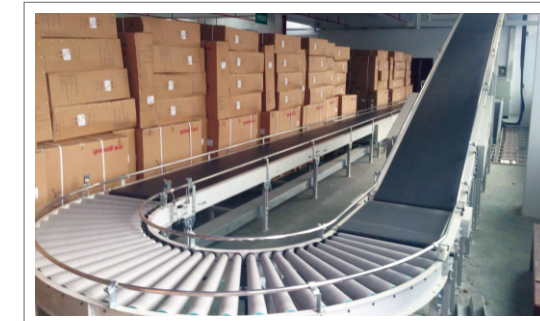

多楔带转弯滚筒输送机  
Multi Wedge Turning Roller Conveyor

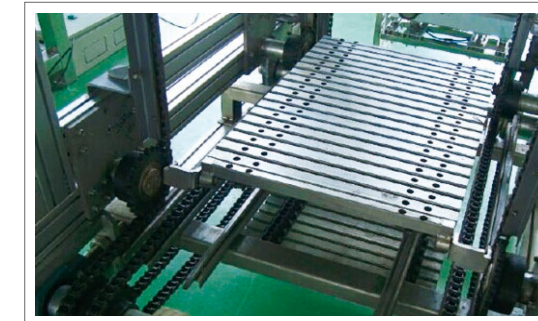

连续式提升机  
Continuous Hoist



转向轮分拣机  
Steering Wheel Sorter

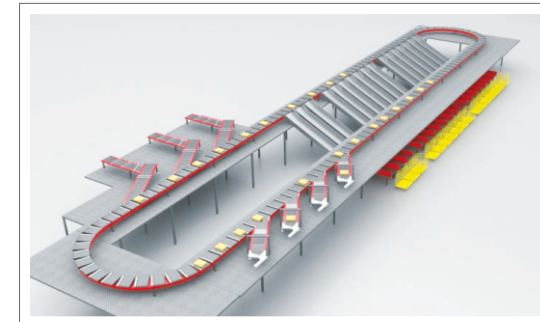

交叉带分拣机  
Cross-Belt Sorter



滑块分拣机  
Slider Sorter

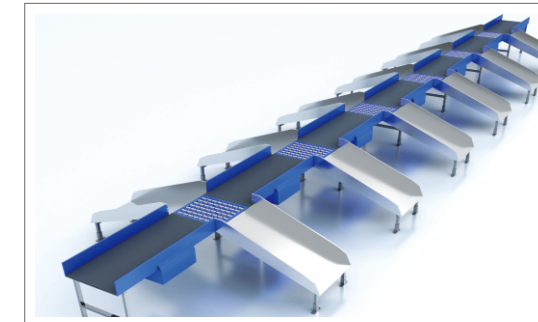

摆轮分拣机  
Swing Wheel Sorter

**托盘式输送系统解决方案**  
Pallet Conveyor System Solutions



旋转台  
Carousel



顶升移栽机  
Jacking Transplanter



拆/码盘机  
Destack/Stack



滚筒输送机  
Roller Conveyor



链条输送机  
Chain Conveyor

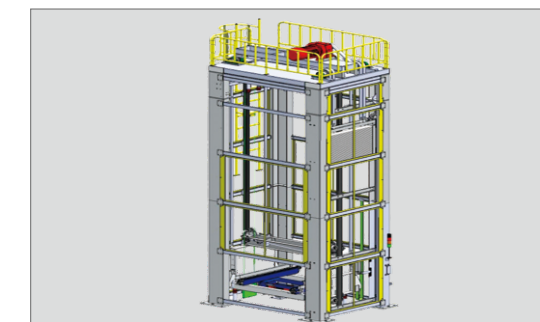

往复垂直输送机提升机  
Reciprocating Vertical Conveyor Elevator

**CIMC TIANDA 中集天达**

创·造·新价值  
Driving New Value

**CIMC TIANDA 中集天达**

智能物流装备产品手册  
Intelligent Logistics Equipment  
Product Manual





## 堆垛机产品介绍 Product Introduction of Stacker

### 功能

沿着高层货架仓库巷道内轨道运行，向货格存取单元货物，完成出入库作业。

### Function

Run along the track at the streetlet of the AS/RS; store the goods in the unit load or pick up the goods from the unit load to complete the warehousing operation.

## 单立柱堆垛机 Single Mast Stacker Crane



可载货物重量/Carrying Weight: ~2000kg

- ◆ 工作环境温度/Operating Temperature: -40 ~ -20°C或-19 ~ 40°C
- ◆ 行走速度/Walking Speed: ~240m/min
- ◆ 行走加速度/Walking Acceleration: 0~0.5m/s<sup>2</sup>
- ◆ 设备高度/Device Height: 45m

应用行业: 化工、医药、家具、新能源、食品、冷库、汽车、化纤等。

Application Industry: Petrochemical, Biological Medicine, Furniture, New Energy, Food, Cold Storage, Automobile, Chemical Fiber, etc.

## 双立柱堆垛机 Double Mast Stacker Crane

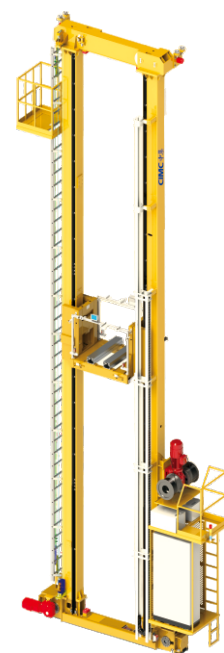

可载货物重量/Carrying Weight: ~2500kg

- ◆ 工作环境温度/Operating Temperature: -40 ~ -20°C或-19 ~ 40°C
- ◆ 行走速度/Walking Speed: ~240m/min
- ◆ 行走加速度/Walking Acceleration: 0~0.5m/s<sup>2</sup>
- ◆ 设备高度/Device Height: 45m

应用行业: 化工、医药、家具、新能源、食品、冷库、汽车、化纤等。

Application Industry: Petrochemical, Biological Medicine, Furniture, New Energy, Food, Cold Storage, Automobile, Chemical Fiber, etc.

01

变频双闭环控制  
运行速度快  
效率高  
Frequency Conversion Double  
Closed Loop Control  
High Running Speed  
High Efficiency

02

模块化设计  
周期短  
质量高  
Modular Design  
Short Cycle  
High Quality

03

选用优质材料和器件  
可靠性高  
寿命长  
Select High Quality Materials  
and Components  
High Reliability  
Long Life Cycle

## 箱式高速堆垛机 High-Speed Miniload Stacker Crane



- ◆ 工作环境温度/Operating Temperature: -40 ~ -20°C、-20 ~ 40°C
- ◆ 行走速度/Walking Speed: ~300m/min
- ◆ 行走加速度/Walking Acceleration: 0~3m/s<sup>2</sup>
- ◆ 设备高度/Device Height: 18m
- ◆ 可载货物重量/Carrying Weight: ~50kg

应用行业: 电子、零售、新能源、汽车配件等。  
Application Industry: Electronics, Retail, New Energy, Auto Parts, etc.

伺服控制  
速度快  
定位准  
效率高  
Servo Control  
High Speed  
Accurate Positioning  
High Efficiency

01

铝合金立柱  
自重轻  
能耗低  
Aluminum Alloy Column  
Light Weight  
Low Energy Consumption

02

聚氨酯轮  
运行噪音低  
Polyurethane Wheel  
Low Running Noise

03

## 超重型堆垛机 Heavy-Duty Stacker Crane



- ◆ 工作环境温度/Operating Temperature: -20 ~ 40°C
- ◆ 行走速度/Walking Speed: ~120m/min
- ◆ 行走加速度/Walking Acceleration: 0~0.3m/s<sup>2</sup>
- ◆ 设备高度/Device Height: 20m
- ◆ 可载货物重量/Carrying Weight: ~30000kg

- ◆ 承载大，最大30吨。
- ◆ 货物尺寸适应广，货物长度或宽度可达12m。
- ◆ 运行稳定可靠。

- ◆ Maximum Load Weight: 30tons.
- ◆ Suitable for Many Cargo Sizes, Cargo Length or Width up to 12m.
- ◆ Stable and Reliable Operation.

应用行业: 航空货库、重型板料库、工程机械零配件库等。  
Application Industry: Air Cargo Warehouse, Heavy Plate Warehouse, Spare Parts Warehouse, etc.

## RGV产品介绍 Product Introduction of Rail Guided Vehicle

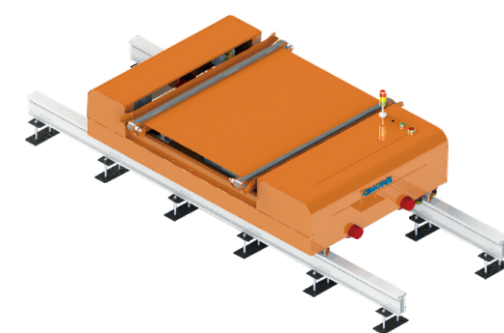

### 直穿系统 Straight Rail Shuttle System

- ◆ 采用模块化设计，故障率低。
- ◆ 维护便利。
- ◆ 行走噪声更小，运行平稳。
- ◆ 完善的运行状态提示条和故障报警显示。
- ◆ Modular design, low failure rate.
- ◆ Easy to maintain.
- ◆ Low walking noise; smooth operation.
- ◆ Perfect operation status prompt and fault alarm display.

### 环穿系统 Circular Rail Shuttle System

- ◆ 行走噪声小，运行平稳。
- ◆ 从动轮自适应轨道，转弯段轨道不需做异形。
- ◆ 行走轮采用回转支承，实现转向，选型稳定可靠。
- ◆ 完善的运行状态提示条和故障报警显示。
- ◆ Low walking noise; smooth operation.
- ◆ Driven wheel adaptive track, turn section track does not need to do anomalous.
- ◆ The walking wheel adopts slewing bearing to realize the steering, and the selection is stable and reliable.
- ◆ Perfect operation status prompt and fault alarm display.

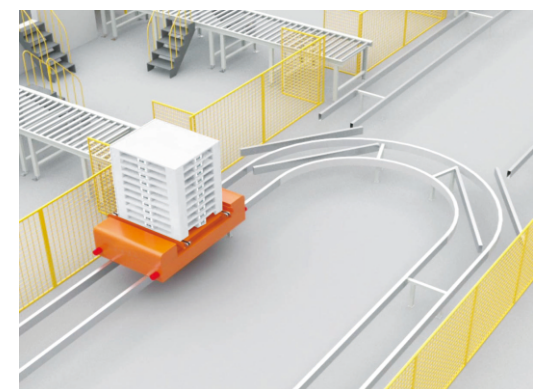

## 多穿车产品介绍 Product Introduction of Multi-Level Shuttle

### 双向多层穿梭车 Two-Way Multi-Level Shuttle

#### 应用方式

在立体仓库每条巷道内配置一台或多台双向多层穿梭车，在立体仓库的一端配置一台穿梭车提升机，通过穿梭车提升机实现穿梭车在立体仓库的不同层高之间切换取放货物。

#### Application

One or more two-way multi-level shuttles are configured in each roadway of the stereoscopic warehouse, and a shuttle elevator is configured at one end of the stereoscopic warehouse.

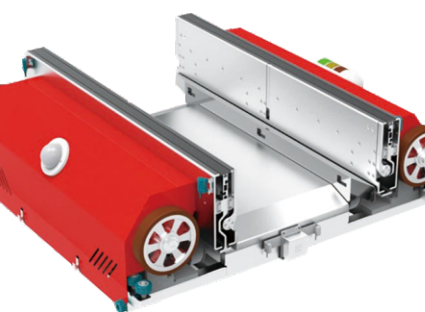

- ◆ 适用产品类型/Product Type: 硬料箱、纸箱/Hard Material Boxes, Cardboard Boxes
- ◆ 适用产品规格/Product Specifications: Max: 600\*400\*600 (mm) Min: 200\*200\*100 (mm)
- ◆ 货物重量/Cargo Weight: ≤50kg

- ◆ 外形尺寸/Outside Dimensions: 双深位/Double Deep Storage: 1050\*970\*325 (mm) 单深位/Single Deep Storage: 1050\*720\*325 (9mm)
- ◆ 巷道宽度/Span Length: 双深位/Double Deep Storage: 1025 (mm) 单深位/Single Deep Storage: 775 (mm)

## 提升机产品介绍 Product Introduction of Elevator

### 高速料箱提升机 High-Speed Workbin Elevator



- ◆ 工作环境温度/Operating Temperature: -20°C~40°C
- ◆ 提升方式/Lifting Mode: 往复式/Reciprocating
- ◆ 提升速度/Lifting Speed: 0~360m/min
- ◆ 提升加速度/Lifting Acceleration: 0~6 m/s<sup>2</sup>
- ◆ 提升高度/Lifting Height: 0.45m~23m
- ◆ 取放货速度/Expansion and Retraction Speed of Fork: 0~60m/min
- ◆ 可载货物重量/Carrying Weight: ≤100kg/单侧/Single Side

#### 应用方式

多层自动生产装配线或者立体仓储，实现货物多楼层快速输送或高低落差输送。在多层穿梭车立库内，配合穿梭车，实现货物高速出库、入库、移库。

#### Application

Multi-layer automatic production assembly line or stereoscopic warehouse, realized multi-floor delivery or high and low delivery. Cooperate with shuttle to realize ex-warehouse, warehouse, warehouse shifting in high-speed.

### 穿梭车换层提升机 Shuttle Elevator

- ◆ 工作环境温度/Operating Temperature: -5°C~40°C
- ◆ 提升方式/Lifting Mode: 往复式/Reciprocating
- ◆ 提升速度/Lifting Speed: 0~180m/min
- ◆ 提升加速度/Lifting Acceleration: 0~3 m/s<sup>2</sup>
- ◆ 提升高度/Lifting Height: 0.45m~23m
- ◆ 可载货物重量/Carrying Weight: ≤250kg

#### 应用方式

在多层立体仓库内，并不是每层都布置穿梭车，为了实现穿梭车在不同层之间切换取放货物，会在立体仓库的每条巷道一端配置一台穿梭车提升机，通过穿梭车提升机实现穿梭车在立体仓库的不同层高之间切换取放货物。

#### Application

In stereoscopic warehouse, shuttle are not arranged on each floor. In order to achieve shuttle access to the goods between different layers, a shuttle elevator will be configured at one side of each roadway of the stereoscopic warehouse. So that, it can achieve the access to the goods between different floors.



### 四向多层穿梭车 Four-Way Multi-Level Shuttle

#### 应用方式

根据立体仓库的货物吞吐量配置四向多层穿梭车，在立体仓库的一端配置一台穿梭车提升机，通过穿梭车提升机实现穿梭车在立体仓库的不同层高之间切换取放货物。

#### Application

Four-way multi-level shuttle is configured according to the cargo handling capacity of the warehouse. A shuttle elevator is configured at one side of the stereoscopic warehouse. Through the shuttle elevator, the shuttle can exchange goods between different floors of the stereoscopic warehouse.



- ◆ 适用产品类型/Product Type: 硬料箱、纸箱/Hard Material Boxes, Cardboard Boxes
- ◆ 适用产品规格/Product Specifications: Max: 600\*400\*600 (mm) Min: 200\*200\*100 (mm)

- ◆ 货物重量/Cargo Weight: ≤50kg
- ◆ 外形尺寸/Outside Dimension: 1330\*970\*300 (mm)
- ◆ 巷道宽度/Streetlet Length: 1025 (mm)